

**BEST OF
CLASS**



The Jewell LCF Series Inclinometer is a $\pm 1^\circ$ to $\pm 90^\circ$ device designed for applications where high levels of shock and vibration are present. LCF units are characterized by excellent turn on repeatability and very low hysteresis.

LCF-100 Series Flexure Suspension Servo Fluid Damped Inclinometer Specifications

Performance

Input Range, ° (Note 1)	± 1.0	± 14.5	± 30	± 90
Full Range Output (FRO), VDC $\pm 0.5\%$	± 5.0	± 5.0	± 5.0	± 5.0
Nonlinearity, % FRO max (Note 2)	0.05	0.02	0.02	0.05
Scale Factor, volts/g nominal	286.5	20.0	10.0	5.0
Scale Factor Temp Sens, PPM/°C max	100	100	100	100
Natural Frequency, Hz nominal (Note 3)	3	30	30	30
Bandwidth (-3dB), Hz nominal	3	30	30	30
Input Axis Misalignment, ° max	0.15	0.05	1.00	1.00
Bias, volts max	0.500	0.100	0.100	0.050
Zero Tilt Temp Sens, volts/°C max	0.015	0.001	0.0005	0.0003
Resolution and Threshold, μ rad max	1	1	1	1

Electrical

Input Voltage, VDC	± 12 to ± 18
Input Current, mA nominal	± 15
Output Impedance, ohms nominal	100
Noise, Vrms, max	0.002

Environmental

Operating Temp Range	-40 to +80°C
Survival Temp Range	-60 to +90°C
Vibration	20 grms
Shock	1000g, 1 msec, $\frac{1}{2}$ sine
Seal	Epoxy

NOTE 1: Full Range is defined as “from negative full input angle to positive full input angle.”
The Inclinometer output is proportional to the sine of the tilt angle.

NOTE 2: Referenced to theoretical sine value independent of misalignment.

NOTE 3: Output phase angle = -90° .

Applications

- Geophysical Testing
- Railcar Acceleration Control
- Platform Orientation

LCF-100 Series Flexure Suspension Servo Fluid Damped Inclinometer

Block Diagram

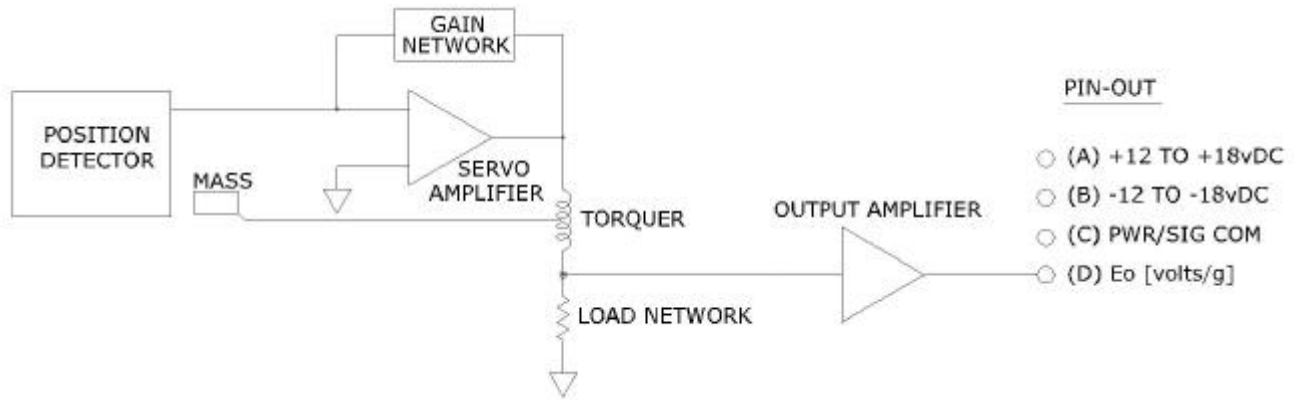

Outline Diagram

