

SV-SERIES

SV-Series

Dual In Line Package

mV Output

Temperature Compensated

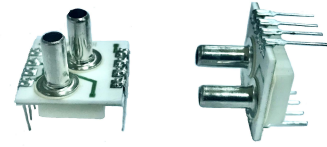

DESCRIPTION

APPLICATIONS

SV-Series is a temperature compensated, mV output, ceramic mounted pressure sensor packaged in a rugged Dual In Line package. SV-Series uses a silicon MEMS pressure sensor bonded to a ceramic substrate containing thick film resistors that are uniquely laser trimmed for each sensor.

Incorporating a flexible design, the SV-Series is available with no, short or long tubes and can be mounted pin up or pins down to allow OEM to optimize their board design. The SV-Series is powered using constant voltage and when configured as in the application note, the integrated gain set resistor will ensure sensor field interchangeability.

The SV-Series superior die performance, coupled with rugged ceramic substrate ensures long term stability with superior temperature performance over wide operating range.

- Pneumatic controls
- Automotive diagnostics
- Medical equipment/instrumentation
- Air Speed and Altitude
- Environmental controls
- Barometric pressure measurement
- Factory Automation
- Process Controls

FEATURES

- 0.1% Pressure Non Linearity
 - Constant Voltage
 - Wide selection of port
 - Absolute, Differential or Gage pressures
 - Temperature Compensated
 - 100% Field Interchangeability
-

SV-SERIES

Specifications	Min	Typical	Max	Unit	Note
Supply Voltage	Application Schematic			V	
Span (5~300PSI)	49.5	50	50.5	mV	1
Span (1~2PSI)	39.5	40	40.5	mV	1
Zero Pressure Output	-2	-	2	mV	
Pressure Non Linearity	-0.2	0.1	0.2	%FS	
Hysteresis & Repeatability	-0.15	0.1	0.15	%FS	
Input/Output Resistance	2.5	5	6.5	KΩ	
Temperature Error – Zero	-0.5	0.2	0.5	%FS	2
Temperature Error – Span	-0.5	0.3	0.5	%FS	2
Resistance Temperature Coefficient	0.25	0.3	0.35	%/°C	
Long Term Stability	-	0.25	-	%FS	
Response Time	-	1	-	ms	
Weight	-	≈3	-	g	
Compensation Temperature	-20		70	°C	
Operating Temperature	-40		100	°C	
Storage Temperature	-50		125	°C	
Overage Pressure	3X				
Wetted Materials	Dry, non-corrosive gas				

Reference Conditions: Vsupply: Constant Voltage, Ta=25°C.

- 1、 All specification at reference conditions unless otherwise noted.
- 2、 Maximum temperature error between -20°C and +70°C with respect to 25°C

EQUIVALENT CIRCUIT

APPLICATION CIRCUIT

CONSTANT VOLTAGE

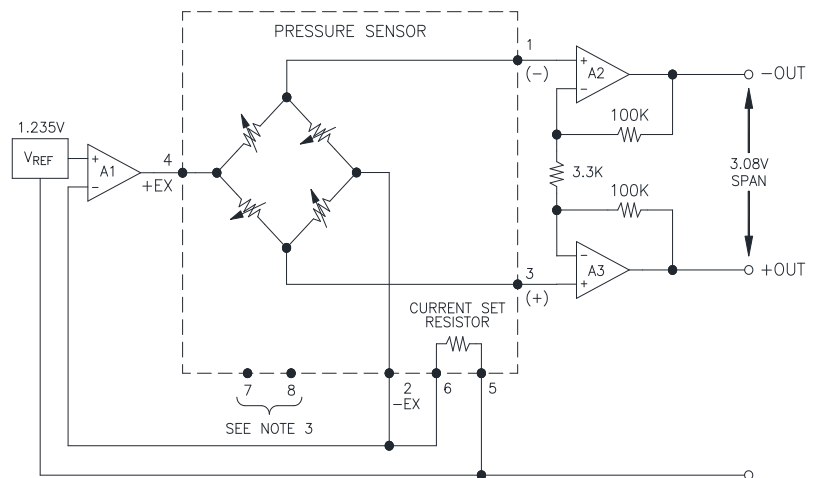
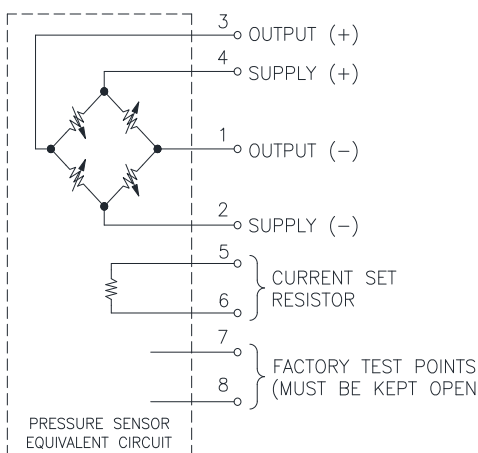

APPLICATION SCHEMATIC

SV-SERIES

MECHANICAL DIMENSIONS in [mm]

METAL TUBE/CERAMIC SUBSTRATE AND LID

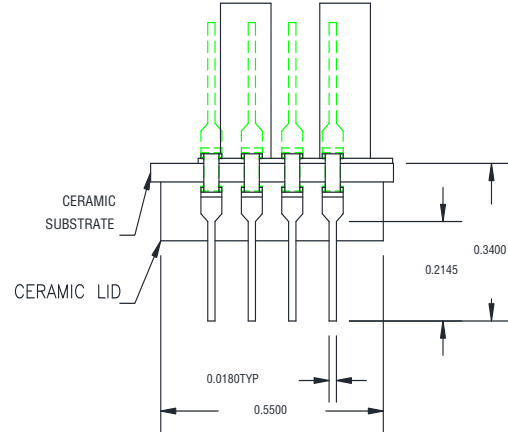
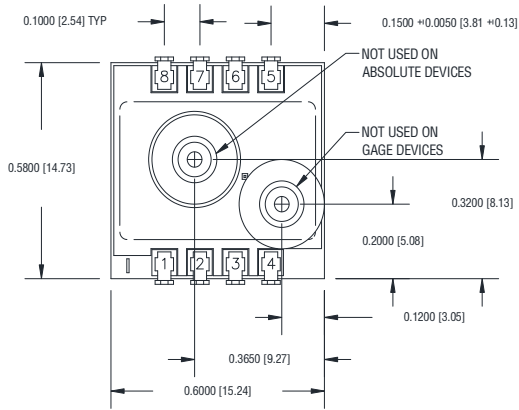

PAD NO	FUNCTION
1	-OUT
2	-EX
3	+OUT
4	+EX
5,6	GAIN
7,8	TEST

PART NUMBERING FOR ORDERS

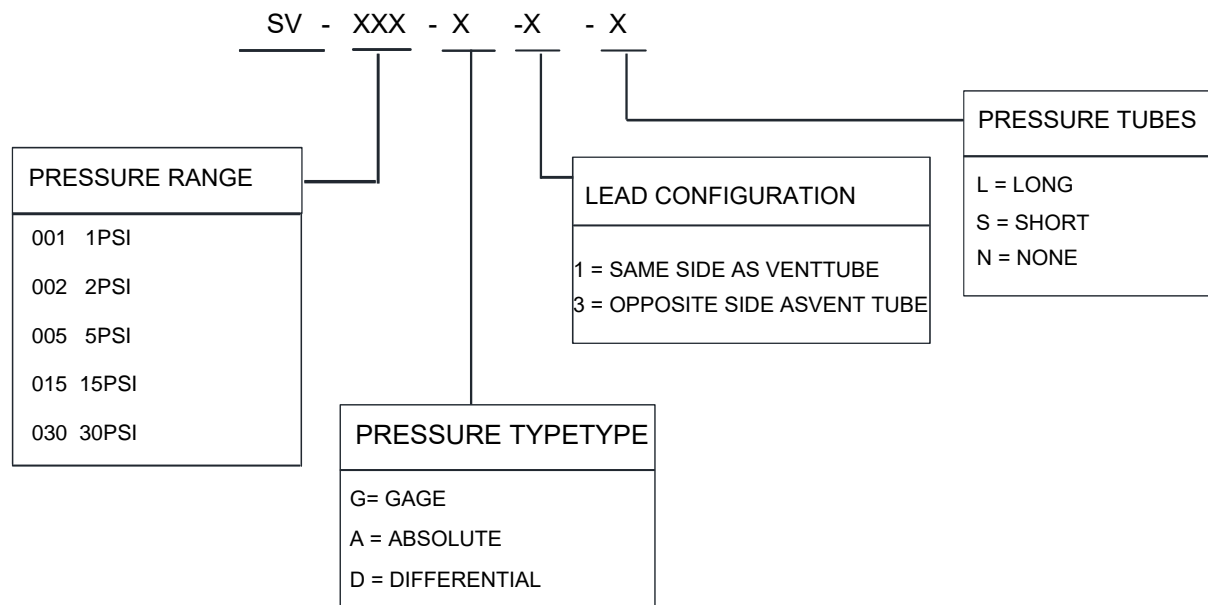

Part Number Example: SV-015A Product

S-Series 15PSI ABSOLUTE