

ADVANCED INFORMATION

MS4515HRD (High Resolution Digital)



- **Integrated Digital Pressure Sensor (24-bit $\Delta\Sigma$ ADC)**
- **Fast Conversion Down to 1 ms**
- **Low Power, 1 μA (standby < 0.15 μA)**
- **Supply Voltage: 1.8 to 3.6V**
- **Pressure Range: 2 to 20inH₂O**
- **I²C and SPI Interface up to 20 MHz**
- **No External Components (Internal Oscillator)**

DESCRIPTION

The MS4515HRD is a new generation of high resolution digital pressure sensors from MEAS with SPI and I²C bus interface. The sensor module includes a high linearity pressure sensor and an ultra low power 24-bit $\Delta\Sigma$ ADC with internal factory calibrated coefficients. It provides a precise digital 24-bit pressure and temperature value and different operation modes that allow the user to optimize for conversion speed and current consumption. A high resolution temperature output allows the implementation of a thermometer function without any additional sensor. The MS4515HRD can be interfaced to virtually any microcontroller. The communication protocol is simple, without the need of programming internal registers in the device.

This new sensor module generation is based on leading MEMS technology and latest benefits from MEAS proven experience and know-how in high volume manufacturing of pressure modules, which have been widely used for over a decade. The sensing principle employed leads to very low hysteresis and high stability of both pressure and temperature signal

FEATURES

- Inch Water Pressure Ranges
- PCB Mountable
- Digital Output
- Barbed Pressure Ports

APPLICATIONS

- Factory Automation
- Altitude and Airspeed Measurements
- Medical Instruments
- Leak Detection

STANDARD RANGES (inH₂O)

Range	Gauge	Differential
2	--	DS
4	DS	DS
5	DS	DS
10	DS	DS
20	DS	DS
30	DS	DS

See Package Configurations: DS= Dual Side Port

ADVANCED INFORMATION

MS4515HRD (High Resolution Digital)

BLOCK DIAGRAM

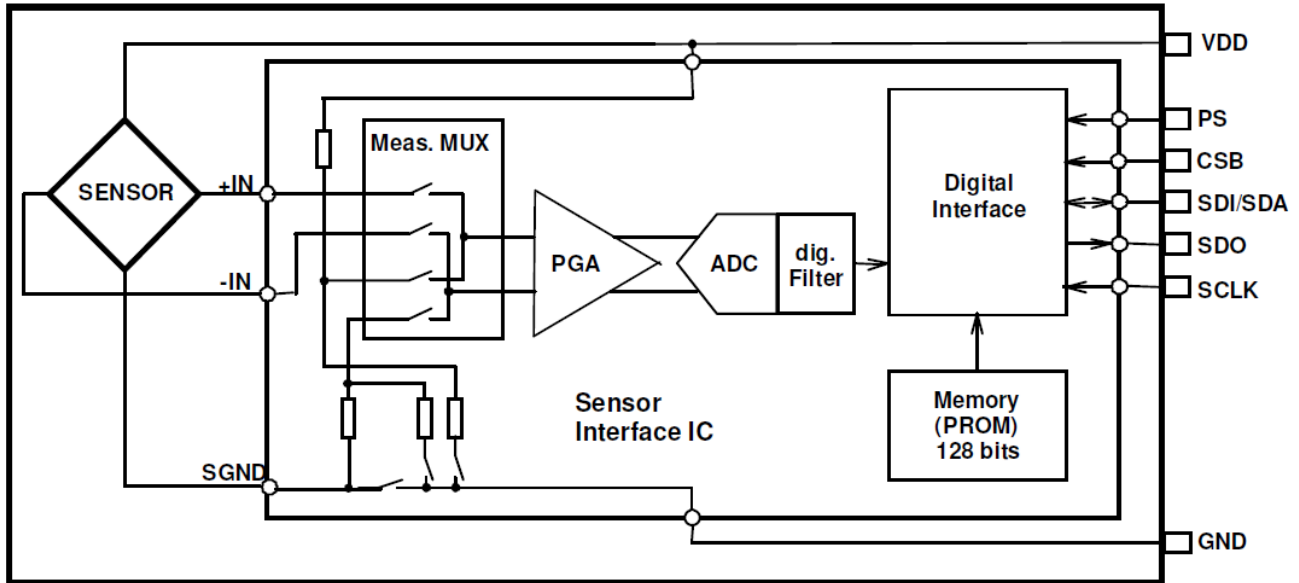

ABSOLUTE MAXIMUM RATING

Parameter	Conditions	Min	Max	Unit	Symbol/Notes
Supply Voltage	$T_A = 25^\circ\text{C}$	1.8	3.6	V	V_{DD}
Output Current	$T_A = 25^\circ\text{C}$				
Storage Temperature		-40	125	$^\circ\text{C}$	
Humidity	$T_A = 25^\circ\text{C}$		95	%RH	Non Condensing
Overpressure	$T_A = 25^\circ\text{C}$, both Ports		300	psi	
Burst Pressure	$T_A = 25^\circ\text{C}$, Port 1			psi	See Table 1
ESD	HBM	-4	+4	kV	EN 61000-4-2
Solder Temperature		250 $^\circ\text{C}$, 5 sec max.			

Table 1- BURST PRESSURE BY RANGE AND PACKAGE STYLE

Range	Gauge	Differential	Unit
002	--	10	psi
004	10	10	psi
005	10	10	psi
010	10	20	psi
020	20	20	psi
030	25	50	psi

ADVANCED INFORMATION

MS4515HRD (High Resolution Digital)

ENVIRONMENTAL SPECIFICATIONS

Parameter	Conditions
Mechanical Shock	Mil Spec 202F, Method 213B, Condition C, 3 Drops
Mechanical Vibration	Mil Spec 202F, Method 214A, Condition 1E, 1Hr Each Axis
Thermal Shock	100 Cycles over Storage Temperature, 30 minute dwell
Life	1 Million FS Cycles
MTTF	>10Yrs, 70 °C, 10 Million Pressure Cycles, 120%FS Pressure

PERFORMANCE SPECIFICATIONS

Supply Voltage¹ 3.0 Vdc

Reference Temperature: 25°C (unless otherwise specified)

PARAMETERS	MIN	TYP	MAX	UNITS	NOTES
ADC			24	bits	
Pressure Accuracy	-0.25		0.25	%FS	2,5
Total Error Band (TEB)	-1.0		1.0	%FS	3
Temperature Accuracy (Reference Temperature)	-0.8		0.8	°C	4,5
Temperature Accuracy	-2.0		2.0	°C	4,5
Supply Current	See OSR Table Below			mA	
Compensated Temperature	-0		60	°C	
Operating Temperature	-25		+105	°C	
Conversion Time	See OSR Table Below			mS	
Weight	3			grams	
Media	Non-Corrosive Dry Gases Compatible with Ceramic, Silicon, Pyrex, PPS, RTV, Gold, Aluminum and Epoxy. See "Wetted Material by Port Designation" chart below.				

Notes

1. Proper operation requires an external capacitor placed as shown in Connection Diagram. Output is not ratiometric to supply voltage.
2. The maximum deviation from a best fit straight line (BFSL) fitted to the output measured over the pressure range at 25°C. Includes all errors due to pressure non linearity, hysteresis, and non repeatability.
3. The maximum deviation from ideal output with respect to input pressure and temperature over the compensated temperature range. Total error band (TEB) includes all accuracy errors, thermal errors over the compensated temperature range, span and offset calibration tolerances. TEB values are valid only at the calibrated supply voltage.
4. The deviation from a best fit straight line (BFSL) fitted to the output measured over compensated temperature range.
5. Ten coefficients must be read by microcontroller software and are used in a mathematical calculation for converting D1 and D2 into compensated pressure and temperature values.

ADVANCED INFORMATION

MS4515HRD (High Resolution Digital)

OVERSAMPLING RATIO (OSR) PERFORMANCE CHARACTERISTICS

SUPPLY CURRENT CHARACTERISTICS

Parameter	Symbol	Conditions	Min.	Typ.	Max	Unit
Supply current (1 sample per sec.)	I_{DD}	OSR 4096		12.5		μA
		2048		6.3		
		1024		3.2		
		512		1.7		
		256		0.9		
Peak supply current		during conversion		1.4		mA
Standby supply current		at 25°C		0.02	0.14	μA

ANALOG DIGITAL CONVERTER (ADC)

Parameter	Symbol	Conditions	Min.	Typ.	Max	Unit
Conversion time	t_c	OSR 4096	7.40	8.22	9.04	ms
		2048	3.72	4.13	4.54	
		1024	1.88	2.08	2.28	
		512	0.95	1.06	1.17	
		256	0.48	0.54	0.60	

TEMPERATURE OUTPUT CHARACTERISTICS ($V_{DD} = 3 V$, $T = 25^\circ C$ UNLESS OTHERWISE NOTED)

Parameter	Conditions	Min.	Typ.	Max	Unit
Resolution RMS	OSR	4096	0.002		$^\circ C$
		2048	0.003		
		1024	0.005		
		512	0.008		
		256	0.012		
Maximum error with supply voltage	$V_{DD} = 1.8 V \dots 3.6 V$	-0.5		+0.5	$^\circ C$

ADVANCED INFORMATION

MS4515HRD (High Resolution Digital)

INPUT/OUTPUT SPECIFICATIONS

DIGITAL INPUTS (CSB, I²C, DIN, SCLK)

Parameter	Symbol	Conditions	Min.	Typ.	Max	Unit
Serial data clock	SCLK	SPI protocol			20	MHz
Input high voltage	V _{IH}	Pins CSB	80% V _{DD}		100% V _{DD}	V
Input low voltage	V _{IL}		0% V _{DD}		20% V _{DD}	V
Input leakage current	I _{leak25°C} I _{leak85°C}	at 25°C			0.15	μA
Input capacitance	C _{IN}				6	pF

PRESSURE OUTPUTS (I²C, DOUT)

Parameter	Symbol	Conditions	Min.	Typ.	Max	Unit
Output high voltage	V _{OH}	I _{source} = 1.0 mA	80% V _{DD}		100% V _{DD}	V
Output low voltage	V _{OL}	I _{sink} = 1.0 mA	0% V _{DD}		20% V _{DD}	V
Load capacitance	C _{LOAD}				16	pF

ADVANCED INFORMATION

MS4515HRD (High Resolution Digital)

FUNCTIONAL DESCRIPTION

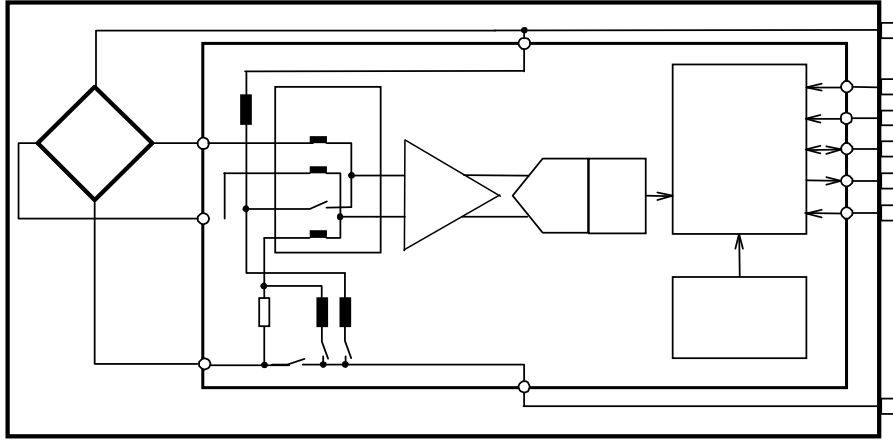

Figure 1: Block diagram of MS4515HRD

GENERAL

The MS4515HRD consists of a piezo-resistive sensor and a sensor interface IC. The main function of the MS4515HRD is to convert the uncompensated analogue output voltage from the piezo-resistive pressure sensor to a 24-bit digital value, as well as providing a 24-bit digital value for the temperature of the sensor.

FACTORY CALIBRATION

Every module is individually factory calibrated at three temperatures and three pressures. As a result, 10 coefficients necessary to compensate for process variations and temperature variations are calculated and stored in the 128-bit PROM of each module. These bits (partitioned into 10 coefficients) must be read by the microcontroller software and used in the program converting D1 and D2 into compensated pressure and temperature values.

SERIAL INTERFACE

The MS4515HRD has built in two types of serial interfaces: SPI and I²C. Pulling the Protocol Select pin PS to low selects the SPI protocol, pulling PS to high activates the I²C bus protocol.

Pin PS	Mode	Pins used
High	I ² C	SDA
Low	SPI	SDI, SDO, CSB

SPI MODE

The external microcontroller clocks in the data through the input SCLK (Serial CLock) and SDI (Serial Data In). In the SPI mode module can accept both mode 0 and mode 3 for the clock polarity and phase. The sensor responds on the output SDO (Serial Data Out). The pin CSB (Chip Select) is used to enable/disable the interface, so that other devices can talk on the same SPI bus. The CSB pin can be pulled high after the command is sent or after the end of the command execution (for example end of conversion). The best noise performance from the module is obtained when the SPI bus is idle and without communication to other devices during the ADC conversion.

MS4515HRD (High Resolution Digital)

I²C MODE & ADDRESSING

The external microcontroller clocks in the data through the input SCLK (Serial CLock) and SDA (Serial DATA). The sensor responds on the same pin SDA which is bidirectional for the I²C bus interface. So this interface type uses only 2 signal lines and does not require a chip select, which can be favorable to reduce board space. In I²C -Mode the complement of the pin CSB (Chip Select) represents the LSB of the I²C address. It is possible to use two sensors with two different addresses on the I²C bus. The pin CSB must be connected to VDD or GND do not leave these pins unconnected.

COMMANDS

The MS4515HRD has only five basic commands:

1. Reset
2. Read PROM (128 bit of calibration words)
3. D1 conversion
4. D2 conversion
5. Read ADC result (24 bit pressure / temperature)

ADVANCED INFORMATION

MS4515HRD (High Resolution Digital)

PRESSURE AND TEMPERATURE CALCULATION

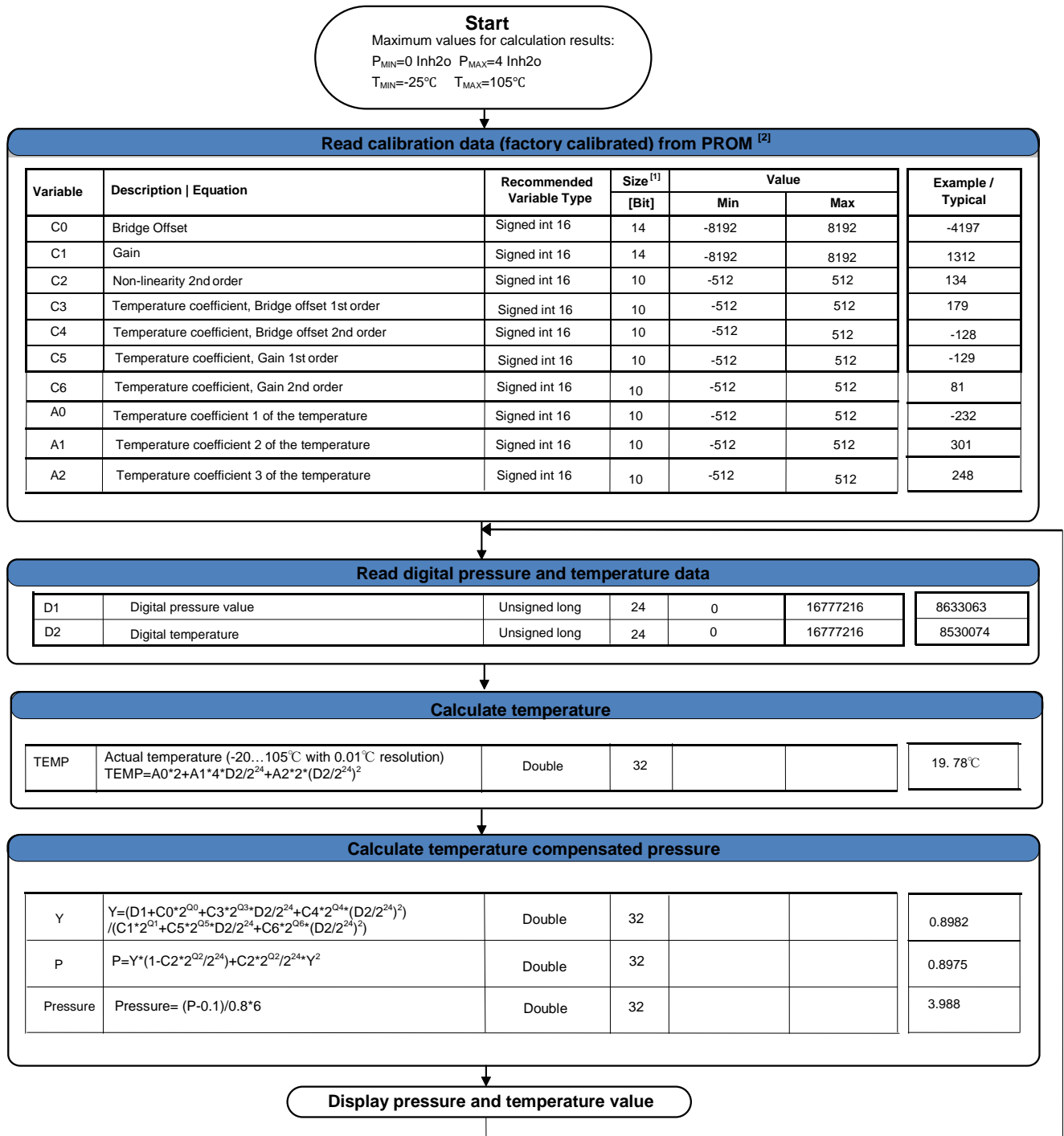

Figure 1: Flow chart for pressure and temperature reading and software compensation.

ADVANCED INFORMATION

MS4515HRD (High Resolution Digital)

MEMORY MAPPING ^[2]

Calibration Coefficients																
Address	15	14	13	12	11	10	9	8	7	6	5	4	3	2	1	0
1	C0 ₁₃	C0 ₁₂	C0 ₁₁	C0 ₁₀	C0 ₀₉	C0 ₀₈	C0 ₀₇	C0 ₀₆	C0 ₀₅	C0 ₀₄	C0 ₀₃	C0 ₀₂	C0 ₀₁	C0 ₀₀	C1 ₁₃	C1 ₁₂
2	C1 ₁₁	C1 ₁₀	C1 ₀₉	C1 ₀₈	C1 ₀₇	C1 ₀₆	C1 ₀₅	C1 ₀₄	C1 ₀₃	C1 ₀₂	C1 ₀₁	C1 ₀₀	C2 ₀₉	C2 ₀₈	C2 ₀₇	C2 ₀₆
3	C2 ₀₅	C2 ₀₄	C2 ₀₃	C2 ₀₂	C2 ₀₁	C2 ₀₀	C3 ₀₉	C3 ₀₈	C3 ₀₇	C3 ₀₆	C3 ₀₅	C3 ₀₄	C3 ₀₃	C3 ₀₂	C3 ₀₁	C3 ₀₀
4	C4 ₀₉	C4 ₀₈	C4 ₀₇	C4 ₀₆	C4 ₀₅	C4 ₀₄	C4 ₀₃	C4 ₀₂	C4 ₀₁	C4 ₀₀	C5 ₀₉	C5 ₀₈	C5 ₀₇	C5 ₀₆	C5 ₀₅	C5 ₀₄
5	C5 ₀₃	C5 ₀₂	C5 ₀₁	C5 ₀₀	C6 ₀₉	C6 ₀₈	C6 ₀₇	C6 ₀₆	C6 ₀₅	C6 ₀₄	C6 ₀₃	C6 ₀₂	C6 ₀₁	C6 ₀₀	A0 ₀₉	A0 ₀₈
6	A0 ₀₇	A0 ₀₆	A0 ₀₅	A0 ₀₄	A0 ₀₃	A0 ₀₂	A0 ₀₁	A0 ₀₀	A1 ₀₉	A1 ₀₈	A1 ₀₇	A1 ₀₆	A1 ₀₅	A1 ₀₄	A1 ₀₃	A1 ₀₂
7	A1 ₀₁	A1 ₀₀	A2 ₀₉	A2 ₀₈	A2 ₀₇	A2 ₀₆	A2 ₀₅	A2 ₀₄	A2 ₀₃	A2 ₀₂	A2 ₀₁	A2 ₀₀	CRC			

Figure 2: Calibration Coefficient Mapping.

Q factor Table by Pressure Range

Pmin to Pmax	Q0	Q1	Q2	Q3	Q4	Q5	Q6
-2 to +2	11	9	10	12	12	13	13
0 to 4	11	9	11	14	14	14	14
-4 to +4	11	9	11	12	12	14	14
0 to 5	11	9	10	12	12	13	13
-5 to +5	11	9	10	12	12	13	13
0 to 10	11	9	10	12	12	13	13
-10 to +10	11	9	10	12	12	13	13
0 to 15	10	11	9	14	14	15	15
-15 to +15	11	9	10	12	12	13	13
0 to 20	11	9	10	12	12	13	13
-20 to +20	11	9	10	12	12	13	13
0 to 30	11	9	10	12	12	13	13
-20 to +30	11	9	10	12	12	13	13

Notes

- [1] Maximal size of intermediate result during evaluation of variable
- [2] All coefficients are 2's complement format

ADVANCED INFORMATION

MS4515HRD (High Resolution Digital)

SPI INTERFACE

COMMANDS

Size of each command is 1 byte (8 bits) as described in the table below. After ADC read commands the device will return 24 bit result and after the PROM read 16bit result. The address of the PROM is embedded inside of the PROM read command using the Ad₂, Ad₁ and Ad₀ bits.

Bit number	Command byte								hex value
	0	1	2	3	4	5	6	7	
Bit name	PRM	COV	-	Typ	Ad2/ Os2	Ad1/ Os1	Ad0/ Os0	Stop	
Command									
Reset	0	0	0	1	1	1	1	0	0x1E
Convert D1 (OSR=256)	0	1	0	0	0	0	0	0	0x40
Convert D1 (OSR=512)	0	1	0	0	0	0	1	0	0x42
Convert D1 (OSR=1024)	0	1	0	0	0	1	0	0	0x44
Convert D1 (OSR=2048)	0	1	0	0	0	1	1	0	0x46
Convert D1 (OSR=4096)	0	1	0	0	1	0	0	0	0x48
Convert D2 (OSR=256)	0	1	0	1	0	0	0	0	0x50
Convert D2 (OSR=512)	0	1	0	1	0	0	1	0	0x52
Convert D2 (OSR=1024)	0	1	0	1	0	1	0	0	0x54
Convert D2 (OSR=2048)	0	1	0	1	0	1	1	0	0x56
Convert D2 (OSR=4096)	0	1	0	1	1	0	0	0	0x58
ADC Read	0	0	0	0	0	0	0	0	0x00
PROM Read	1	0	1	0	Ad2	Ad1	Ad0	0	0xA0 to 0xAE

Figure 4: Command structure

RESET SEQUENCE

The Reset sequence shall be sent once after power-on to make sure that the calibration PROM gets loaded into the internal register. It can be also used to reset the device ROM from an unknown condition

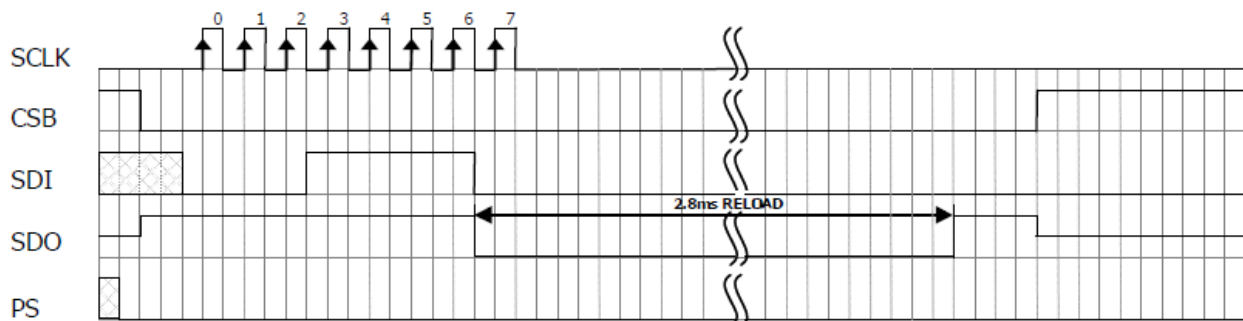

Figure 5: Reset command sequence SPI mode 0

ADVANCED INFORMATION

MS4515HRD (High Resolution Digital)

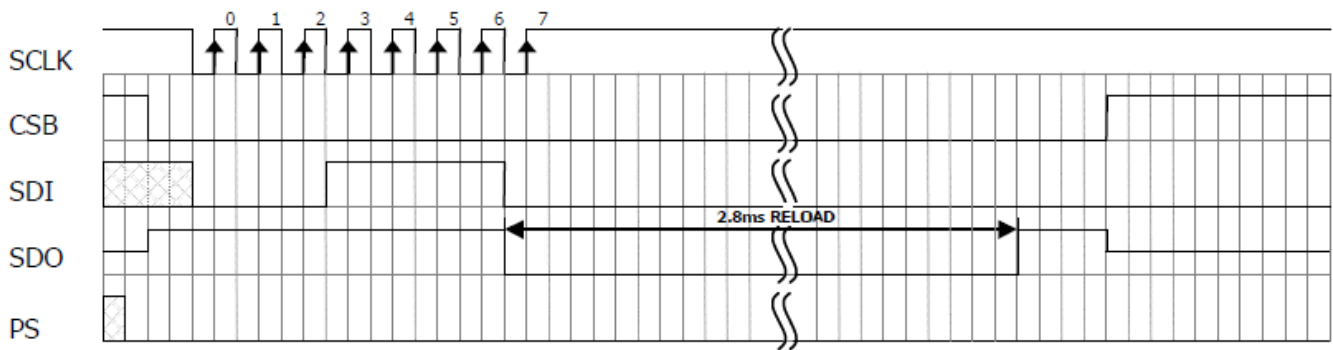

Figure 6: Reset command sequence SPI mode 3

CONVERSION SEQUENCE

The conversion command is used to initiate uncompensated pressure (D1) or uncompensated temperature (D2) conversion. The chip select can be disabled during this time to communicate with other devices. After the conversion, using ADC read command the result is clocked out with the MSB first. If the conversion is not executed before the ADC read command, or the ADC read command is repeated, it will give 0 as the output result. If the ADC read command is sent during conversion the result will be 0, the conversion will not stop and the final result will be wrong. Conversion sequence sent during the already started conversion process will yield incorrect result as well.

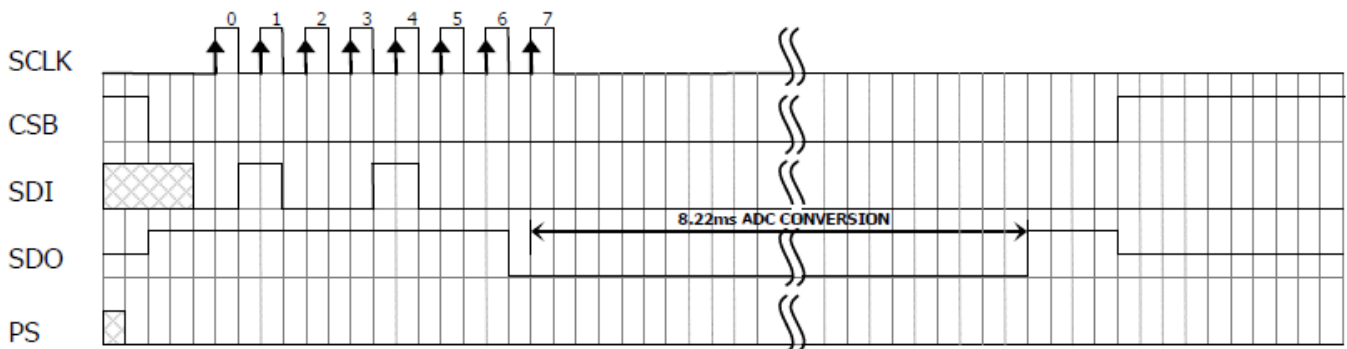

Figure 7: Conversion out sequence, Typ=d1, OSR = 4096

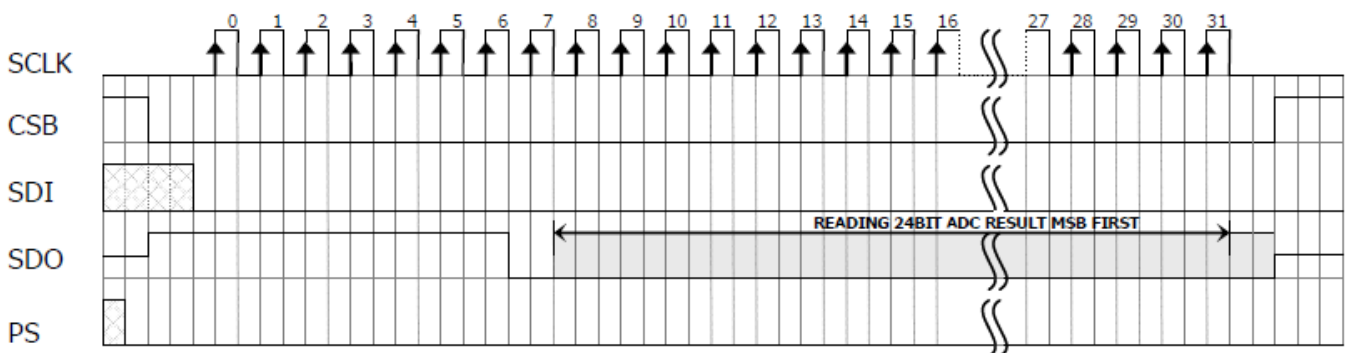

Figure 8: ADC Read sequence

ADVANCED INFORMATION

MS4515HRD (High Resolution Digital)

PROM READ SEQUENCE

The read command for PROM shall be executed once after reset by the user to read the content of the calibration PROM and to calculate the calibration coefficients. There are in total 8 addresses resulting in a total memory of 128 bit. Address 0 contains factory data and the setup, addresses 1-6 calibration coefficients and address 7 contains the serial code and CRC. The command sequence is 8 bits long with a 16 bit result which is clocked with the MSB first.

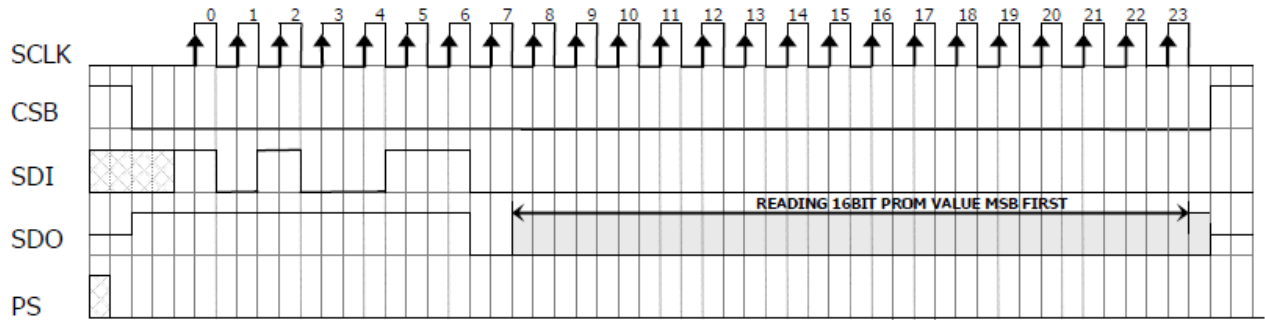

Figure 9: PROM Read sequence, address = 011 (Coefficient 3).

ADVANCED INFORMATION

MS4515HRD (High Resolution Digital)

I²C INTERFACE

COMMANDS

Each I²C communication message starts with the start condition and it is ended with the stop condition. The MS4515HRD address is 111011Cx, where C is the complementary value of the pin CSB. Since the IC does not have a microcontroller inside, the commands for I²C and SPI are quite similar. The command structure is the same as shown in Figure 4 above.

RESET SEQUENCE

The reset can be sent at any time. In the event that there is not a successful power on reset this may be caused by the SDA being blocked by the module in the acknowledge state. The only way to get the MS4515HRD to function is to send several SCLKs followed by a reset sequence or to repeat power on reset.

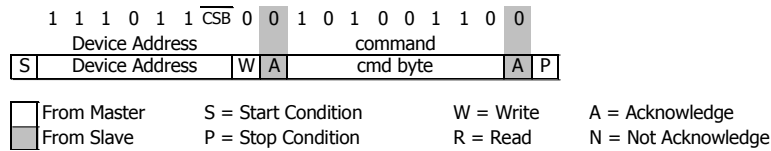

Figure 10: I²C Reset Command

PROM READ SEQUENCE

The PROM Read command consists of two parts. First command sets up the system into PROM read mode. The second part gets the data from the system.

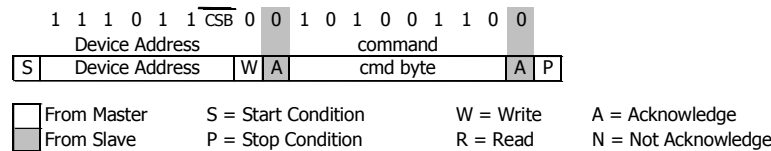

Figure 11: I2C Command to read memory address= 011 (Coefficient 3)

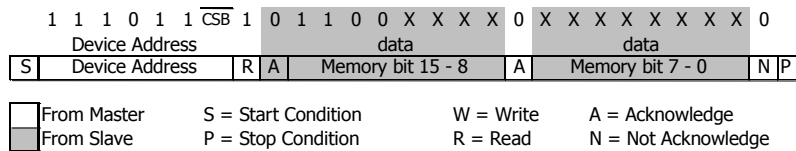

Figure 12: I2C response from MS4515HRD

ADVANCED INFORMATION

MS4515HRD (High Resolution Digital)

CONVERSION SEQUENCE

A conversion can be started by sending the command to MS4515HRD. When command is sent to the system it stays busy until conversion is done. When conversion is finished the data can be accessed by sending a Read command, when an acknowledge appears from the MS4515HRD, 24 SCLK cycles may be sent to receive all result bits. Every 8-bit the system waits for an acknowledge signal.

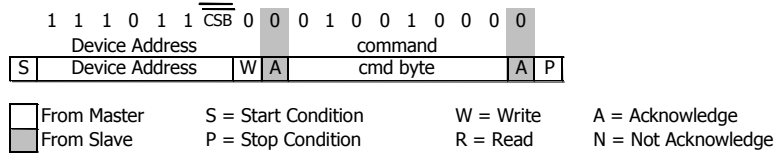

Figure 13: I²C Command to initiate a pressure conversion (OSR=4096, typ=D1)

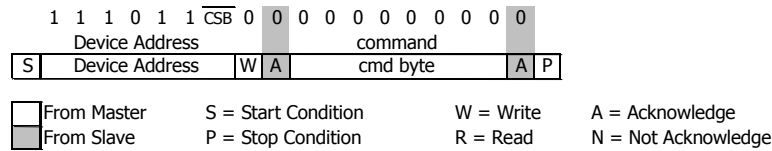

Figure 14: I²C ADC read sequence

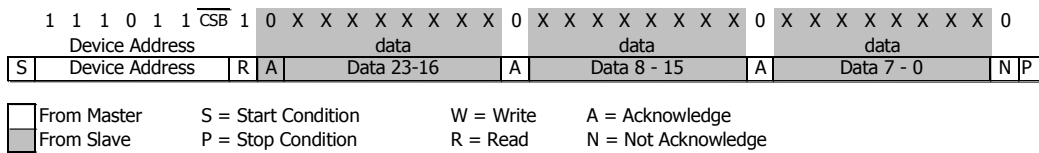

Figure 15: I²C response from MS4515HRD

CYCLIC REDUNDANCY CHECK (CRC)

MS4515HRD contains a PROM memory with 128-Bit. A 4-bit CRC has been implemented to check the data validity in memory. The application note AN520 describes in detail CRC-4 code used.

ADVANCED INFORMATION

MS4515HRD (High Resolution Digital)

APPLICATION CIRCUIT

The MS4515HRD is a circuit that can be used in conjunction with a microcontroller. It is designed for low-voltage systems with a supply voltage of 3 V.

SPI protocol communication

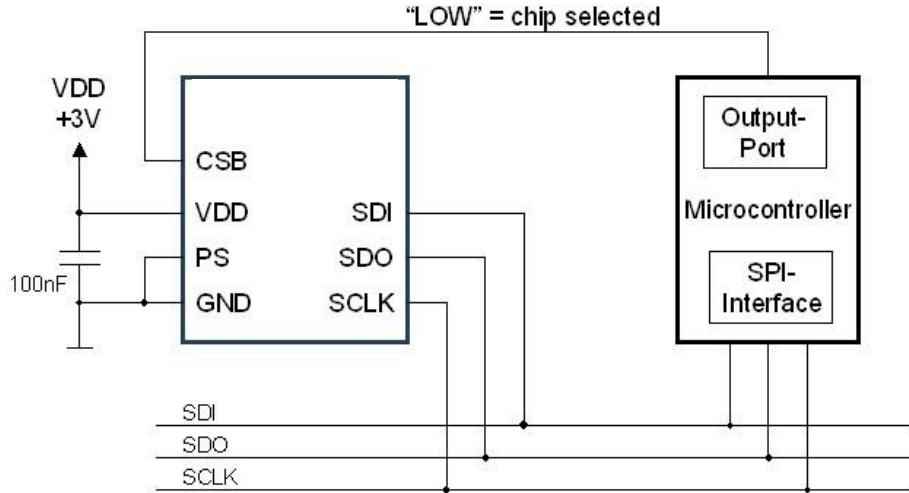

I²C protocol communication

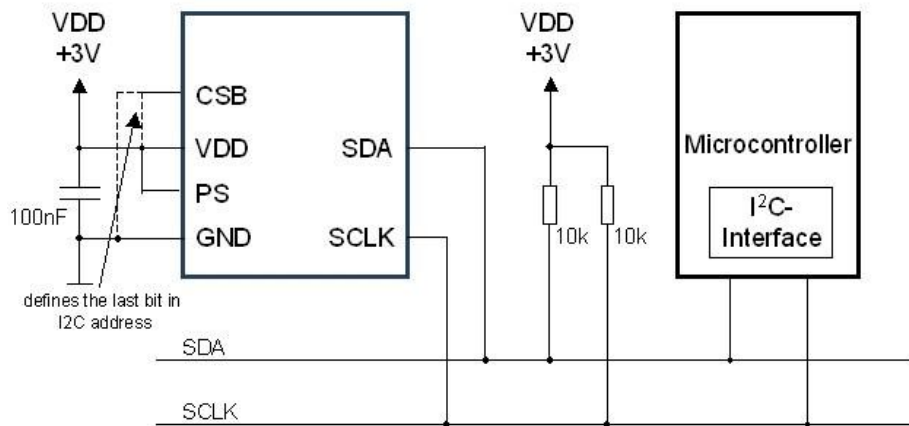

Figure 17: Typical application circuit with SPI / I²C protocol communication

Note

1. Place 100nF capacitor between Supply and GND to within 2 cm of sensor.

ADVANCED INFORMATION
MS4515HRD (High Resolution Digital)

DIMENSIONS

MS4515HRD-DSxxxS

DIMENSIONS ARE IN INCHES [mm]

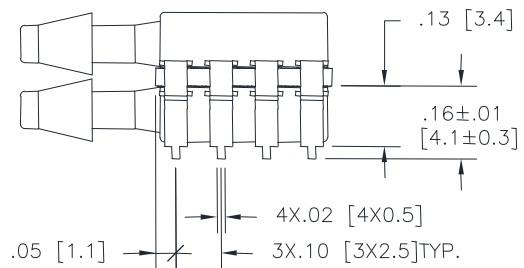
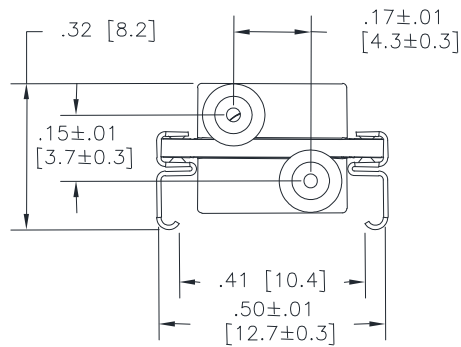
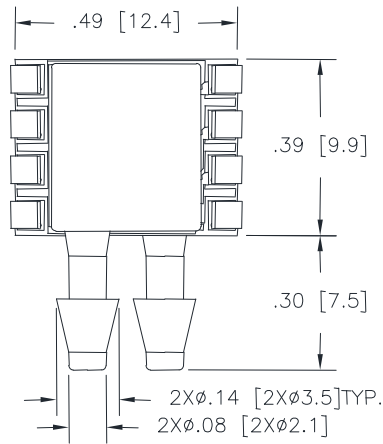

MS4515HRD (High Resolution Digital)

DIMENSIONS

MS4515HRD-DSxxxxP

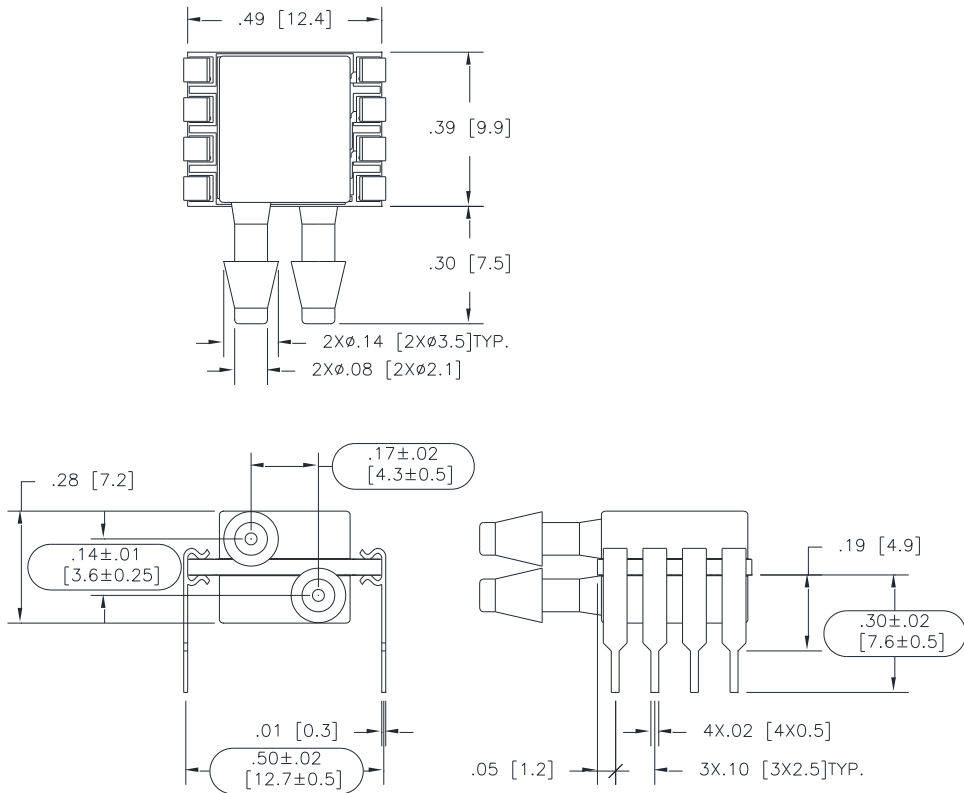

MS4515HRD (High Resolution Digital)

ORDERING INFORMATION

